













Montageanleitung - Assembly instructions- instructions de montage – Montageaawijzing-Istruzioni per l'installazione - indicaciones de montaje - Instruções de instalação- Οδηγίες Εγκατάστασης

Schardt GmbH & Co. KG
Am Riegel 15
96268 Mitwitz
Tel. 09266/9907-0
Fax 09266/9907-77
E-Mail: info@schardt.com

Inhalt - Contents - Contenu - Inhoud - contenuto -contenido-conteúdo - περιεχόμενο
Wickelkommode changing unit Commode Kommode

Wiko Oak 05 252 Typ 1

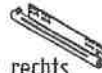
DIN EN 12221:2008+A1:2013

A  8 x	B  15 ohne Rand 8 x			
C  SW 4 1 x	D  14 x	E  2 x		
F  BA 96 6 x	G  M4 x 20 12 x	H  7 x 40 4 x		
K  links SEZ 3 X HD 450 mm	L  rechts SEZ 3 X HD 450 mm	M  6,3 x 10 12 x		
N  1 x Kippschutz				

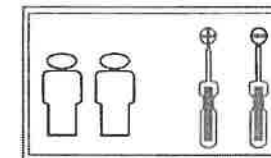

Die Kommode zum Transportieren anheben. Bitte nicht schieben

Lift the cabinet to move it. Please don't push
Til de kast op voor transport. Duw alsjeblieft niet



Montageanleitung - Assembly instructions- instructions de montage – Montageaawijzing-Istruzioni per l'installazione - indicaciones de montaje - Instruções de instalação- Οδηγίες Εγκατάστασης

Schardt GmbH & Co. KG
Am Riegel 15
96268 Mitwitz
Tel. 09266/9907-0
Fax 09266/9907-77
E-Mail: info@schardt.com

Inhalt - Contents - Contenu - Inhoud - contenuto -contenido-conteúdo - περιεχόμενο

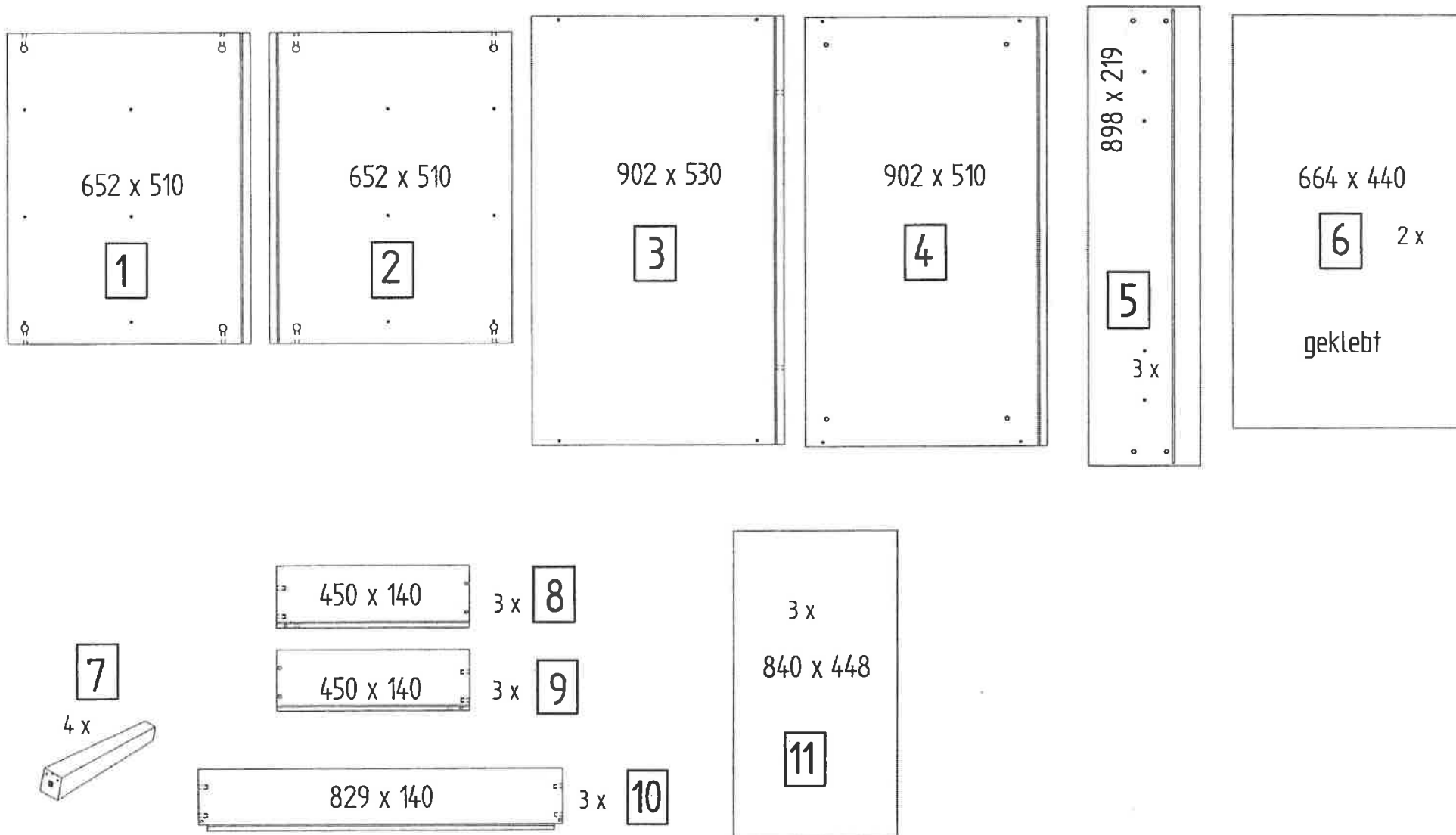

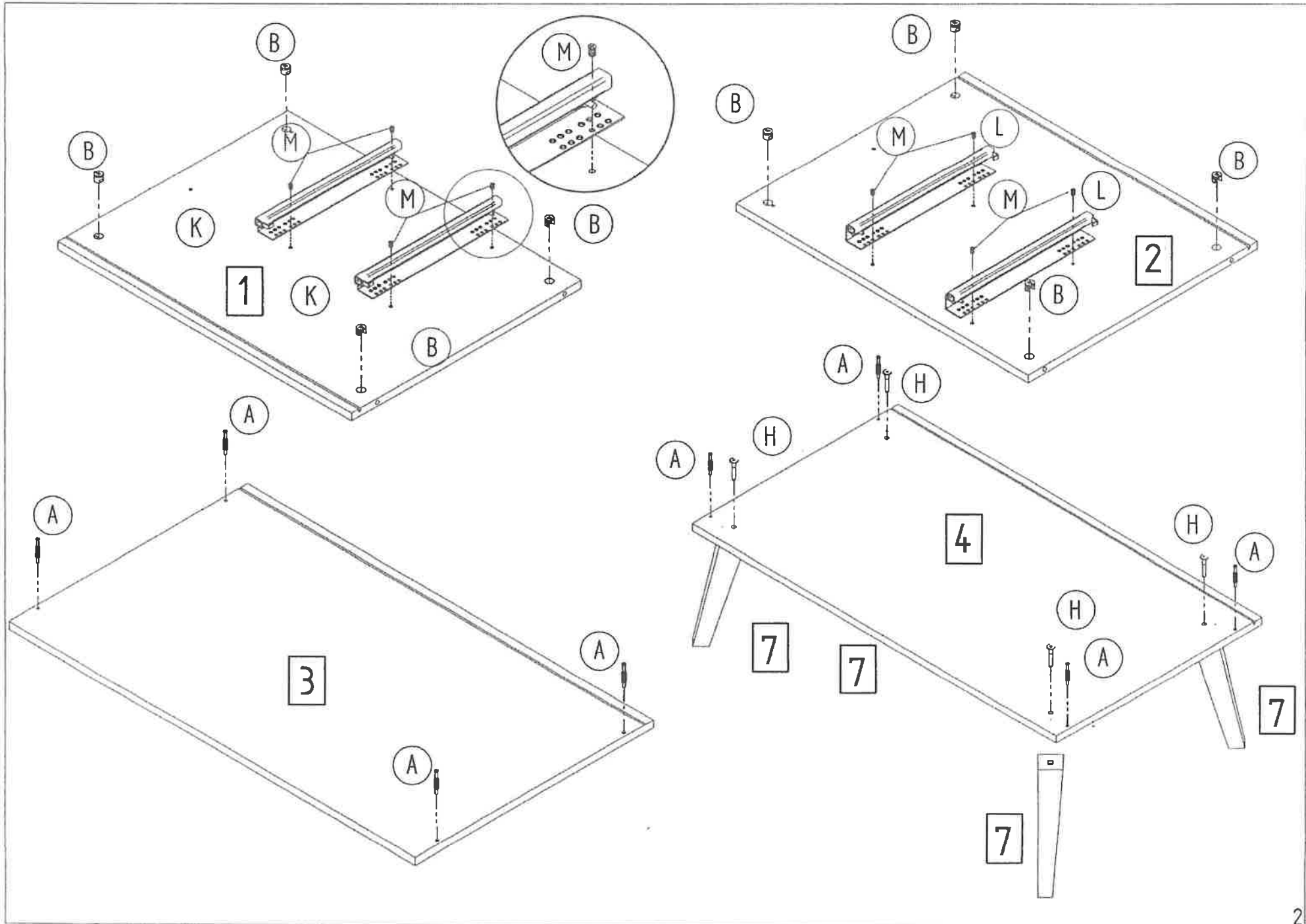

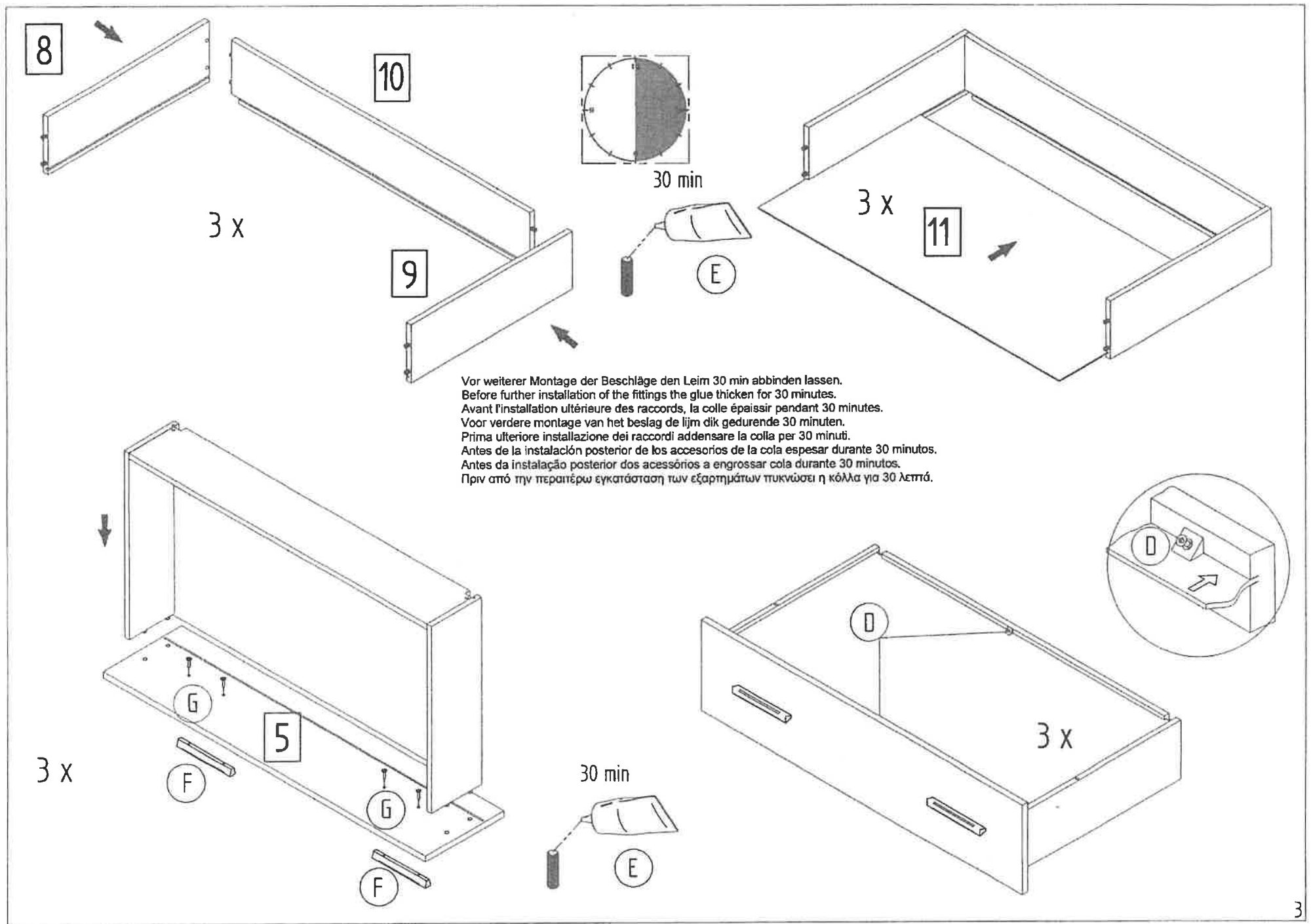

8

10

9

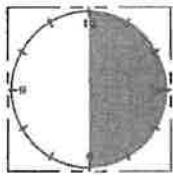

30 min

E

11

3 x

3 x

Vor weiterer Montage der Beschläge den Leim 30 min abbinden lassen.
 Before further installation of the fittings the glue thicken for 30 minutes.
 Avant l'installation ultérieure des raccords, la colle épaissir pendant 30 minutes.
 Voor verdere montage van het beslag de lijm dik gedurende 30 minuten.
 Prima ulteriore installazione dei raccordi addensare la colla per 30 minuti.
 Antes de la instalación posterior de los accesorios de la cola espesar durante 30 minutos.
 Antes da instalação posterior dos acessórios a engrossar cola durante 30 minutos.
 Πριν από την περαιτέρω εγκατάσταση των εξαρτημάτων πυκνώσει η κόλλα για 30 λεπτά.

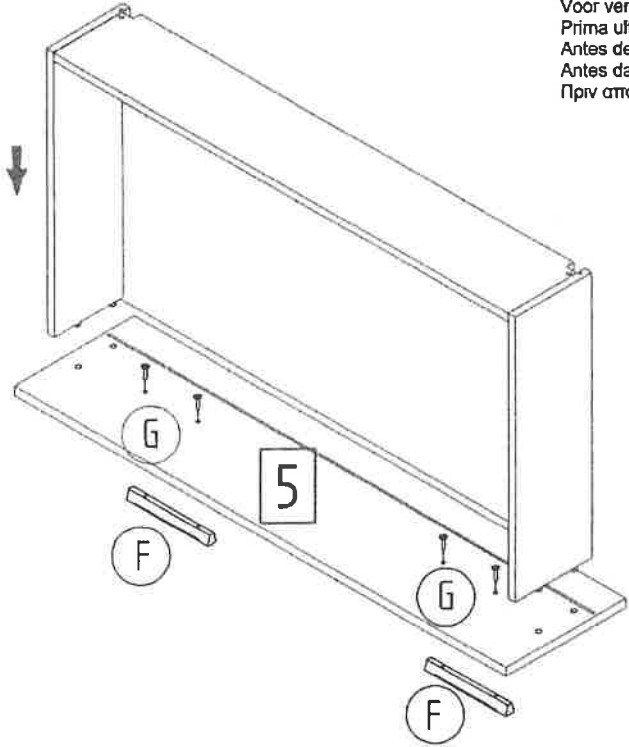

3 x

5

G

F

G

F

30 min

E

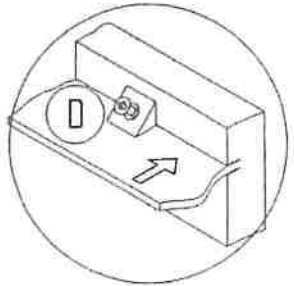

D

3 x

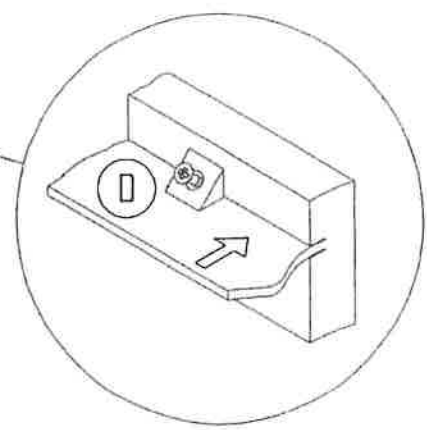
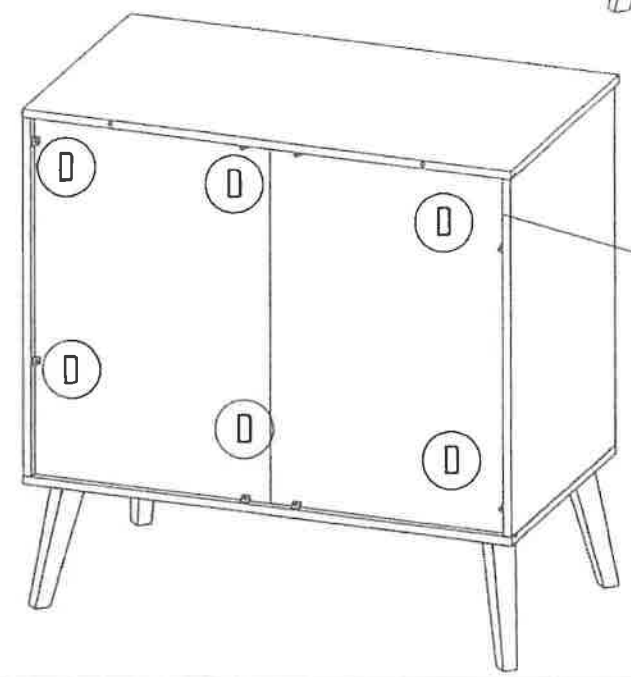
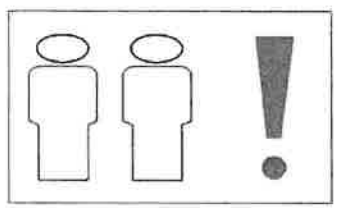
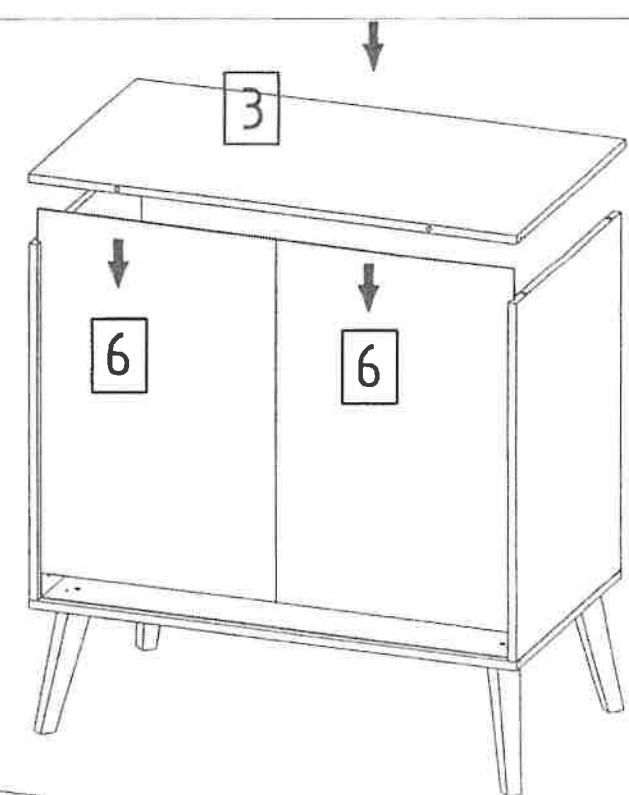
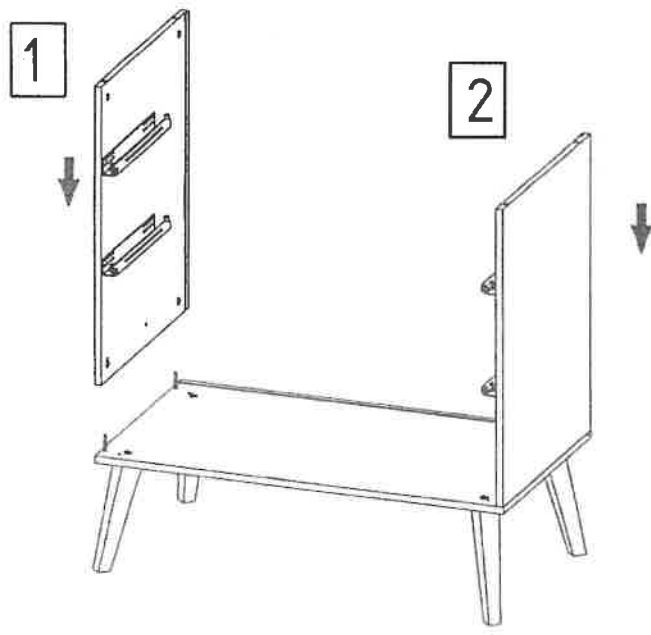

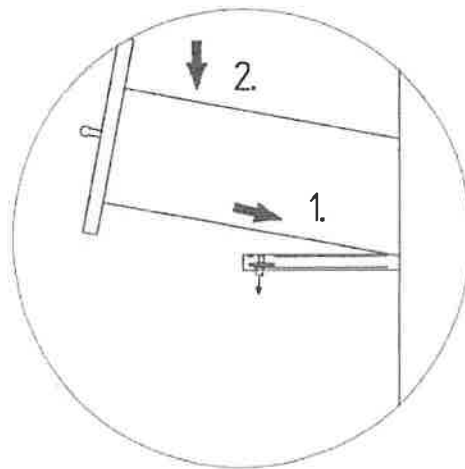
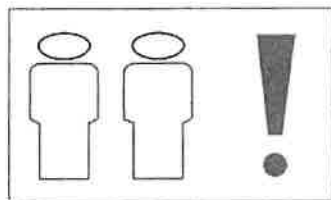
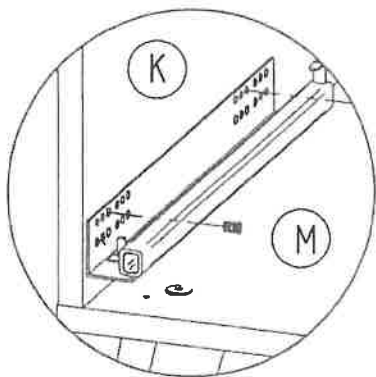
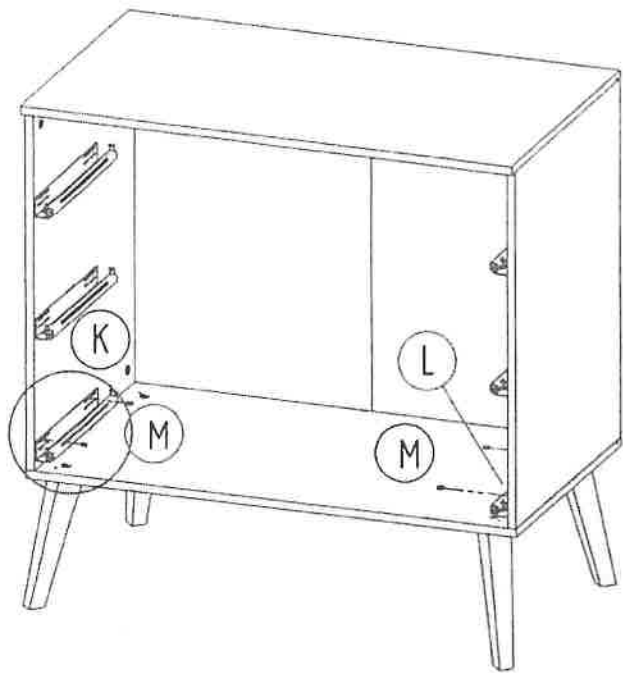



Die Kommode zum Transportieren anheben. Bitte nicht schieben

Lift the cabinet to move it. Please don't push
Til de kast op voor transport. Duw alsjeblieft niet



Achtung !

Wird der Schrank an der Wand befestigt, muss das Montagematerial der Beschaffenheit der Wand entsprechen !

Kippschutz mit Anleitung ist im Beschlagbeutel

Attention !

If the cupboard is attached to the wall the assembly material has to be appropriate for the composition of the wall !

Anti-tip device with instructions is in the fitting bag

Attentie !

Als de kast aan de muur wordt bevestigd, moet het bevestigingsmateriaal overeenkomen met de aard van de muur.

De anti-tipper met instructies zit in de montagezak !

... **weitere Infos über unsere Produkte unter**
... plus d'informations sur nos produits sous
... altre informazione degli prodotti di noi sotto

www.schardt.com



Schardt GmbH & Co. KG
Am Riegel 15
96268 Mitwitz
Tel. 09266/9907-0
Fax 09266/9907-77
E-Mail: info@schardt.com