

Gewächshaus

400HDGH474



Bedienungsanleitung

Sehr geehrte Kundin, sehr geehrter Kunde!

Der Hersteller arbeitet ständig an der Weiterentwicklung aller Typen und Modelle.

Bitte haben Sie Verständnis dafür, dass deshalb jederzeit Änderungen des Lieferumfangs in Form, Ausstattung und Technik möglich sind. Aus den Angaben, Abbildungen und Beschreibung dieser Gebrauchsanweisung können daher keine Ansprüche hergeleitet werden.

Nachdruck, Vervielfältigung oder Übersetzung, auch auszugsweise, ist ohne schriftliche Genehmigung des Herstellers nicht gestattet.

Alle Rechte nach dem Gesetz über das Urheberrecht bleiben dem Hersteller ausdrücklich vorbehalten.

Änderungen vorbehalten.

Einleitung

Machen Sie sich vor der Montage mit dem Produkt vertraut. Lesen Sie hierzu aufmerksam die nachfolgende Montageanleitung und die Sicherheitshinweise. Benutzen Sie das Produkt nur wie beschrieben und für die angegebenen Einsatzbereiche. Bewahren Sie diese Anleitung gut auf. Händigen Sie alle Unterlagen bei Weitergabe des Produkts an Dritte ebenfalls mit aus.

Bestimmungsgemäße Verwendung

Dieses Produkt ist zum kontrollierten Kultivieren von Pflanzen bestimmt. Eine andere Verwendung als zuvor beschrieben oder eine Veränderung des Produkts ist nicht zulässig und kann zu Verletzungen und / oder Beschädigungen des Produkts führen. Für aus bestimmungswidriger Verwendung entstandene Schäden übernimmt der Hersteller keine Haftung. Das Produkt ist nicht für den gewerblichen Einsatz bestimmt.

Sicherheitshinweise

Warnung! Lebens - und Unfallgefahr für Kleinkinder und Kinder!

Lassen Sie Kinder niemals unbeaufsichtigt mit Verpackungsmaterial und Produkt. Es besteht Erstickungsgefahr durch Verpackungsmaterial und Lebensgefahr durch Strangulation. Kinder unterschätzen häufig die Gefahren. Halten Sie Kinder stets vom Produkt fern.

VORSICHT! VERLETZUNG Sgefahr!

Stellen Sie sicher, dass alle Teile unbeschädigt und sachgerecht montiert sind. Bei unsachgemäßer Montage besteht Verletzungsgefahr. Beschädigte Teile können die Sicherheit und Funktion beeinflussen.

VORSICHT!

Lassen Sie Kinder nicht unbeaufsichtigt! Das Produkt ist kein Kletter- oder Spielgerät! Stellen Sie sicher, dass Personen, insbesondere Kinder nicht auf das Produkt klettern bzw. sich nicht am Produkt anlehnen.

Das Produkt könnte aus dem Gleichgewicht kommen und umkippen. Verletzungen und / oder Beschädigungen können die Folgen sein.

Achten Sie darauf, dass das Produkt nur von fachkundigen Erwachsenen montiert wird.

VORSICHT! VERLETZUNG SGEFAHR!

Montieren oder verwenden Sie das Produkt keinesfalls bei starkem Wind.

Entfernen Sie Schnee direkt vom Produkt. Andernfalls kann das Produkt unter dem Gewicht zusammenbrechen.

Stellen Sie sicher, dass Sie das Produkt auf einem festen, ebenerdigen Untergrund platzieren und es fest im Boden verankert ist. Bei Nichtbeachtung drohen Verletzungsgefahr und / oder Beschädigungen am Produkt

Reinigung und Pflege

Reinigen Sie das Produkt mit einem trockenen, fusselreifen Tuch.























































Verwenden Sie bei stärkeren Verschmutzungen ein feuchtes Tuch und ggf. ein mildes Reinigungsmittel.

Verwenden Sie keinesfalls scheuernde oder ätzende Reiniger.







Werkzeuge

Damit Sie Ihr Produkt erfolgreich zusammenbauen können, benötigen Sie einen 10mm und 7mm großen Schraubenschlüssel und einen Schraubendreher.

MONTAGEANWEISUNGEN







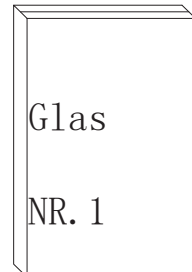



TEIL	NR.	MENGR	TEIL	NR.	MENGR	TEIL	NR.	MENGR	TEIL	NR.	MENGR
	L01A	2		L15	2		A68	1		S35 M6X10	38
	L01B	1		L18A	4		D99	2		S36 M4X6	4
	L01C	1		L18B	2		D101	2		S37 M6X12	2
	L01D	1		L19A	2		D108	2		S38 M6X30	14
	L01E	1		L19B	1		D109	1		M14 M6	38
	L02A	1		L20	1		D117	2		M15 M6	16
	L02B	1		L21A	9		H76	2		M16 M4	4
	L06	1		L22A	6		H77	2		Z03 Ø4X12	2
	L07	1		L23A	1		H78-1	4		Z15 Ø4X12D	66
	L08A	1		L31	1		H78-2	4		Z19 M4.2X10	4
	L08B	1		T01	1		H79 6.5X16X1.2	14			
	L08C	1		T02	1		J121L	1			
	L10A	1					J121R	1			
	L13	2					J119L	1			
	L14A	1					J119R	1			
							J120	1			
							J130	4			



TEIL	NR.	MENGR
	Y1	1
	Y2	1
	Y4	2
	Y7	3
	Y10	1
	Y11	2



Fenster

TEIL	NR.	MENGR
	L19A	2
	L19B	1
	L20	1
	L31	1
	L23A	1
	A68	1
	D108	2
	Y10	1
	Z15 Ø4X12D	8
	S36 M4X6	2
	M16 M4	2

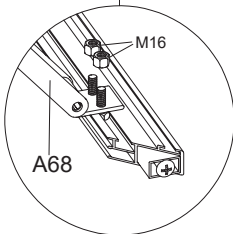
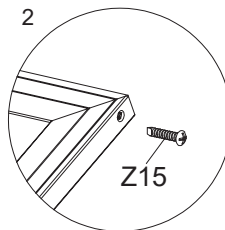
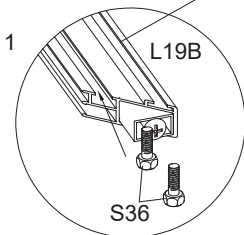
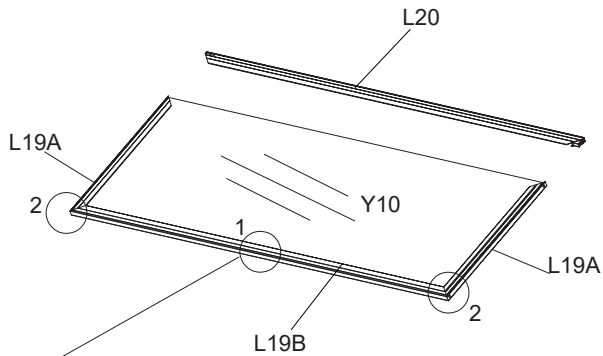

Bringen Sie L19A (2 Stk.) mithilfe von Z15 an L20 & L19B an.

Schieben Sie 2 * S36 in die Mitte des Kanals von L19B, um A68 mithilfe von M16 anzubringen.

Hinweis: Schieben Sie 2 * S36 in den Führungskanal (L19B), bevor Sie L19A und L19B befestigen.

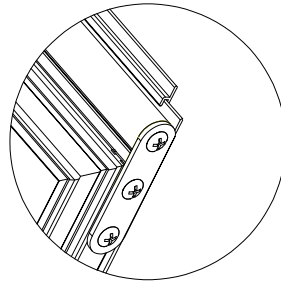
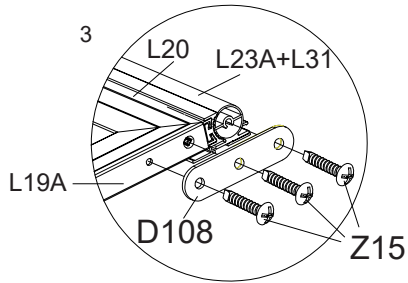

Nach der Installation

Bringen Sie L23A & L31 und L20 mithilfe von D108 und Z15 an (L23A & L31 sind ab Werk miteinander verbunden).

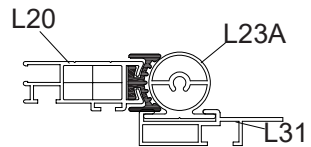

Schnittdarstellung

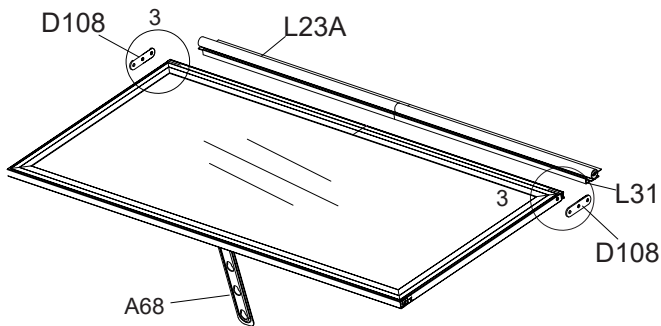

TEIL	NR.	MENGE
	L15	2
	L18A	4
	L18B	2
	Y11	2
	Z15 Ø4X12D	8



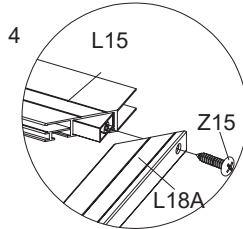
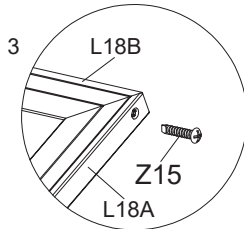
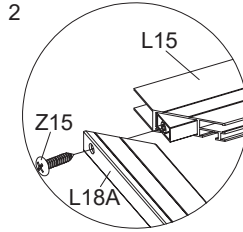
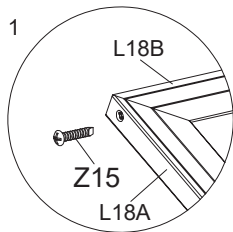

TÜR-Montage (2 STK.)

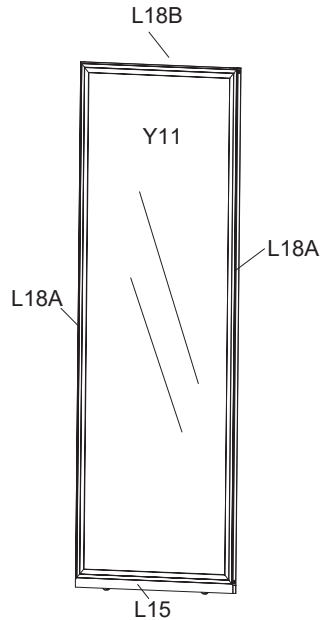
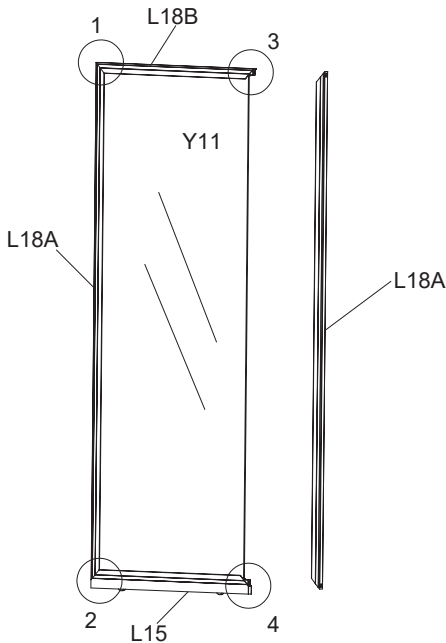

Bringen Sie L18A mithilfe von Z15 an L15 & L18B an, setzen Sie dann das Türblatt Y11 in Position ein. Verwenden Sie abschließend Z15, um eine weitere L18A anzubringen.



Nach der Installation (TÜR - 2 STK.)

TEIL	NR.	MENGE
	L22A	6
	L21A	9
	Z15 Ø4X12D	18
	Y7	3

Regalmontage (3 STK.)

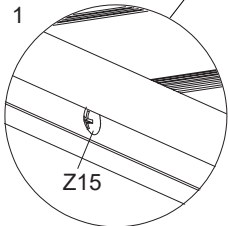
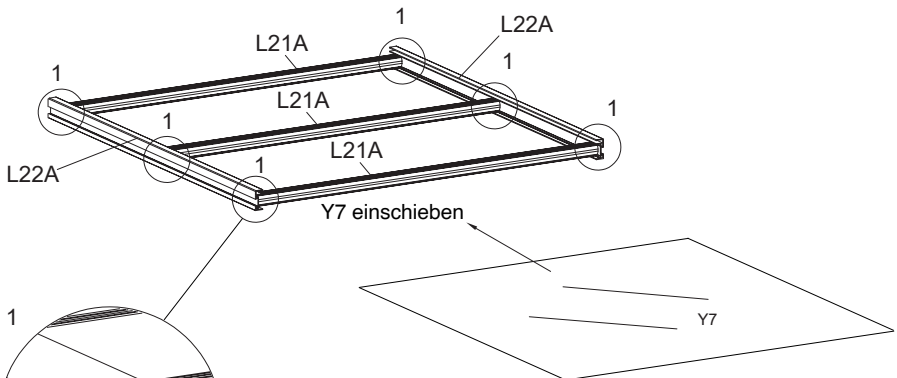



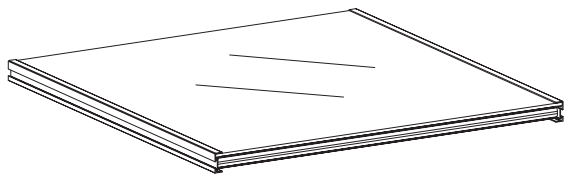









Verwenden Sie Z15,
um L21A und L22A zu verbinden.



Nach der Installation (REGAL - 3 STK.)

HINWEIS: Das Glas ist an beiden Enden nicht gesichert,
bitte darauf achten, dass nach der Installation von Y7, diese nicht herausrutschen.

TEIL	NR.	MENGE
	L08B	1
	L10A	1
	T01	1
	T02	1
	H76	2
	H77	2
	J130	4
	S38	12
	M6X30	12
	M15	12
	M6	12
	H79	12
	6.5X16X1.2	12

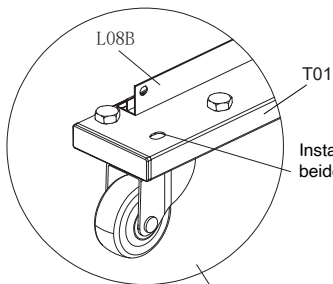
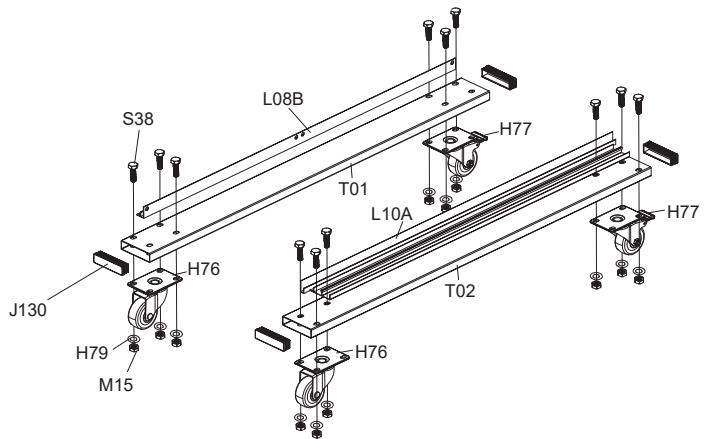

Installieren Sie nicht S38 & M15 & H79 in diesen Löchern an beiden Enden (L08A & L08C werden mithilfe von T01 nachträglich installiert).

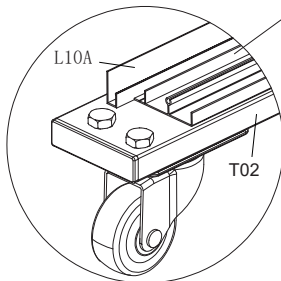
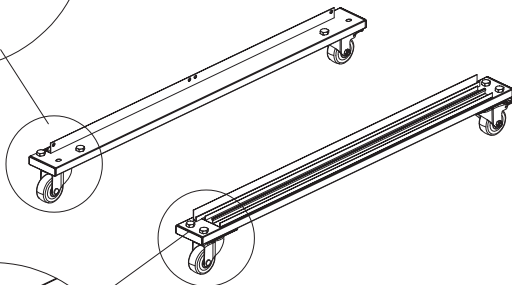

TEIL	NR.	MENGE
	L08A	1
	L08C	1
	L02B	1
	L02A	1
	L01A	2
	L01B	1
	L01C	1
	S35	12
	M6X10	
	M14	12
	M6	
	S38	2
	M6X30	
	M15	2
	M6	
	H79	2
	6.5X16X1.2	

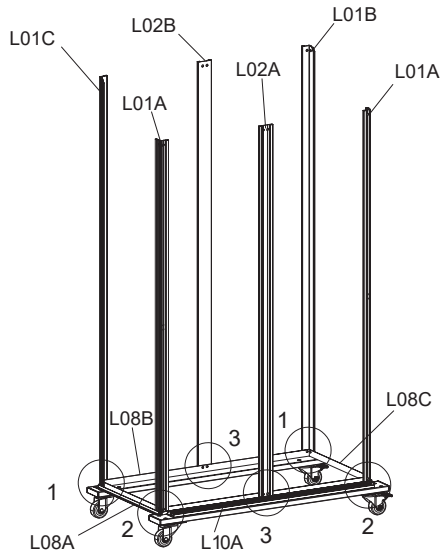

1. Bringen Sie L08A (L08C) mit S38 & H79 & M15 an T01 an, wie dargestellt. Befestigen Sie dann L08A (L08C) & L01C (L01B) & L08B mithilfe von S35/M06 an.

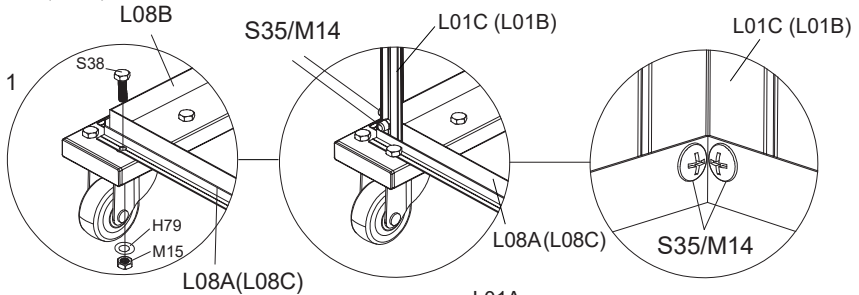

2. Bringen Sie L08A (L08C) mit S35/M06 an L01A & L10A an.

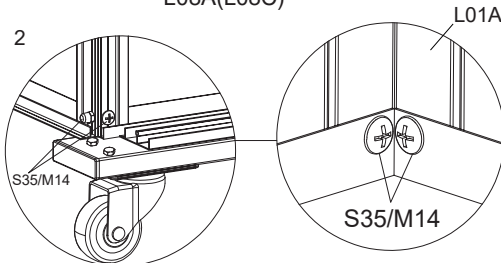

3. Bringen Sie L02A (L02B) mit S35/M06 an L10A (L08B) an.

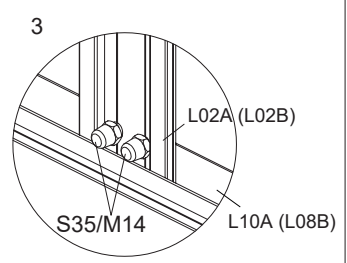



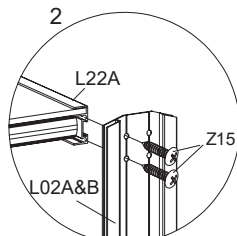
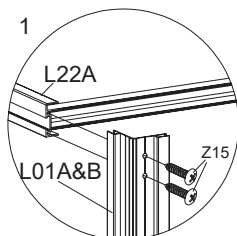



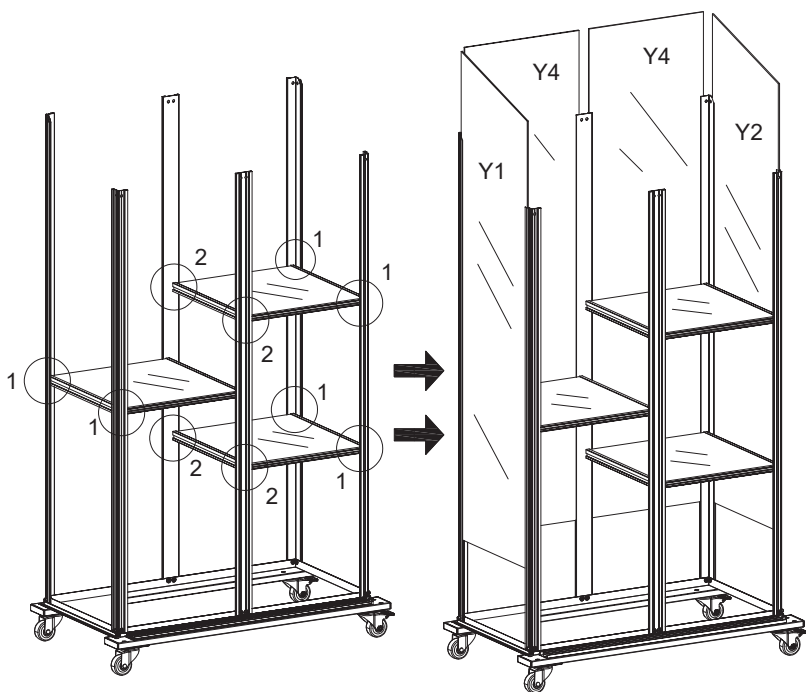

TEIL	NR.	MENGE
	Z15	24
	Ø4X12D	
	Y1	1
	Y2	1
	Y4	2



Bringen Sie L01A&B mit Z15 an L22A (Regale) an.
 Bringen Sie L02A&B mit Z15 an L22A (Regale) an.
 Schieben Sie dann Y4 (2 STK.) & Y1 & Y2 hinein.





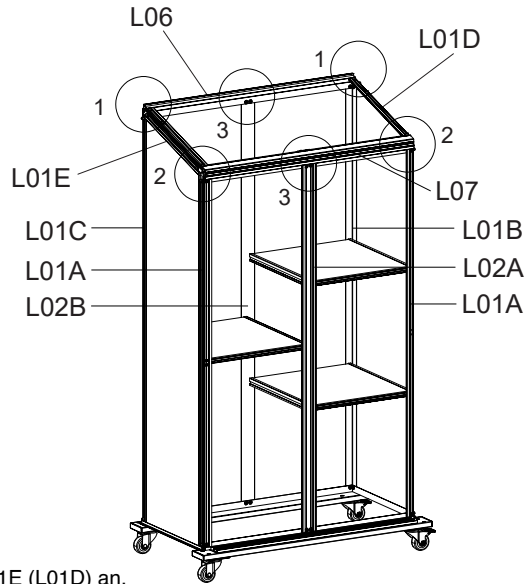

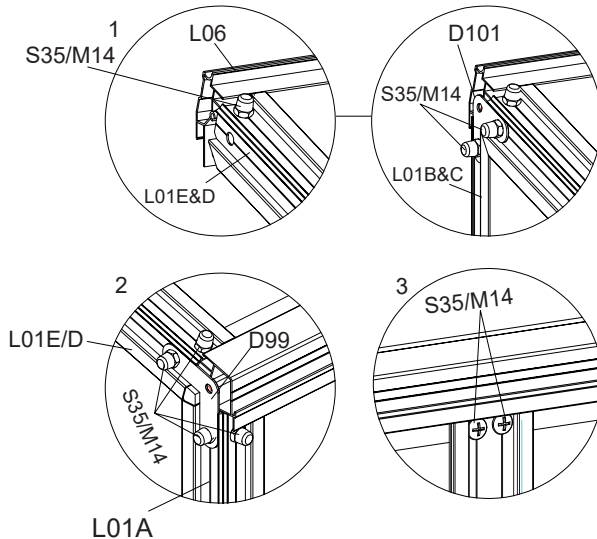

TEIL	NR.	MENGE
	L06	1
	L07	1
	L01D	1
	L01E	1
	D99	2
	D101	2
	S35 M6X10	20
	M14 M6	20



1. Bringen Sie L06 mit S35 & M14 an L01E (L01D) an.
Bringen Sie dann D101 mit S35 & M14 an L01E (L01D) und L01C (L01B) an.
2. Bringen Sie L07 mit S35 & M14 an L01A (L01D).
Bringen Sie dann D99 mit S35 & M14 an L01E (L01D) und L01A an.
3. Bringen Sie L07 mit S35 & M14 an L02A an.



TEIL	NR.	MENGE
	Tür	2
	L14A	1
	L13	2
	Z15 Ø4X12D	4
	Z19 M4.2X10	4
	H78-1	4
	H78-2	4

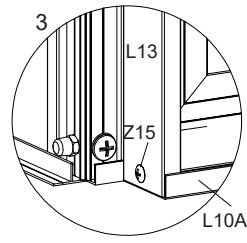
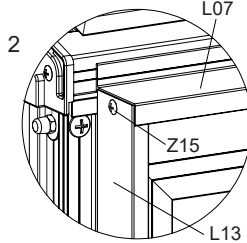
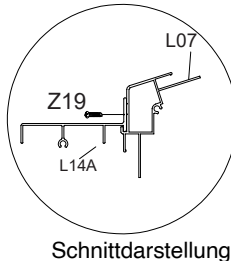
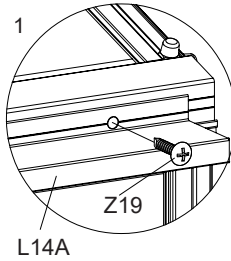





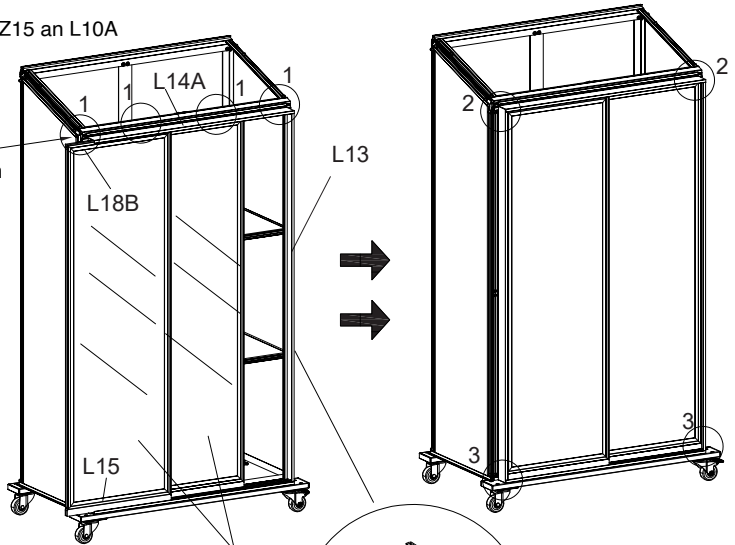



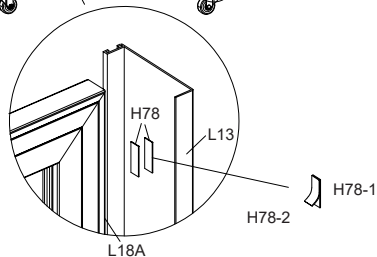







1. Bringen Sie L14A mit Z19 (4 STK.) an L07 an.
(Es ist normal, dass an L07 kein vorgebohrtes Loch vorhanden ist. Um L07 durchzuschrauben, ist ein erhöhter Kraftaufwand erforderlich.)
2. Schieben Sie die Türen in L07 und L10A, bevor Sie L14A mit Z15 (2 Seiten) an L07 anbringen.
3. Bringen Sie L13 mit Z15 an L10A

Schieben Sie die Türen (2 STK.) ein.



Verwenden Sie H78-1, um es an H78-2 festzukleben und daraufhin zusammen an L13 (L18A) festzukleben, wie erforderlich.



TEIL	NR.	MENGE
	Fenster	1
	Z15 Ø4X12D	4
	Z03 Ø4X12	2
	J121L	1
	J121R	1
	J119L	1
	J119R	1
	J120	1
	D109	1
	D117	2
	S35 M6X10	6
	M14 M6	6
	S36 M4X6	2
	S37 M6X12	2
	M15 M6	2
	M16 M4	2

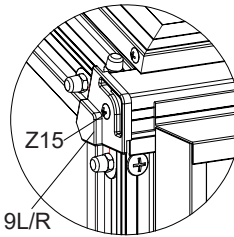
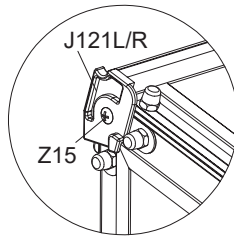

1

2

S35/M14

Befestigen Sie die Abdeckung
J121L/R & J119L/R mit Z15.

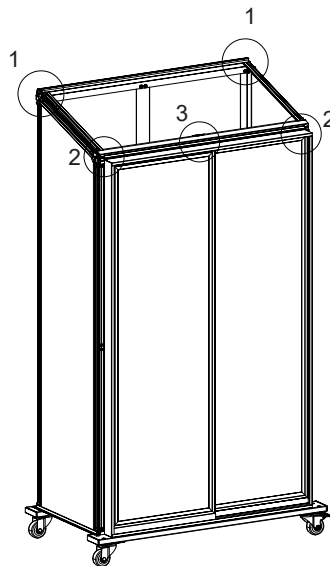
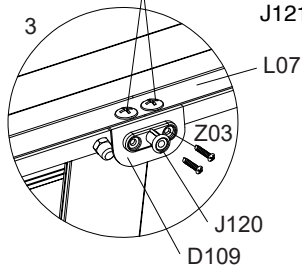

Schieben Sie 2 * S37 in L31, und dann L31 mit M15 & S37 an L06 anbringen.

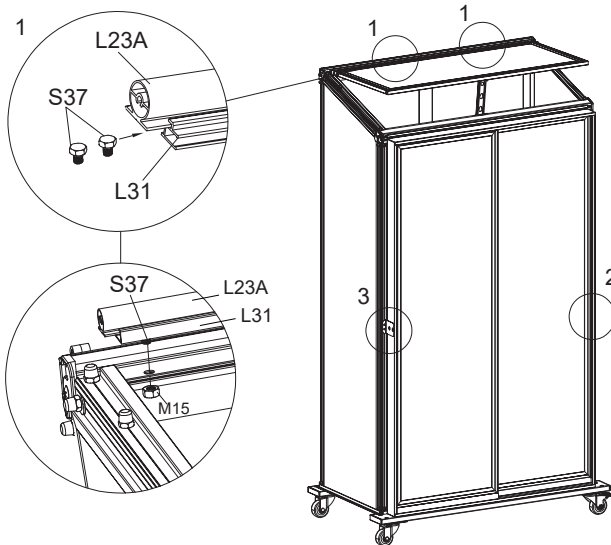

Bringen Sie D117 mit S36 & M16 an L01A an.

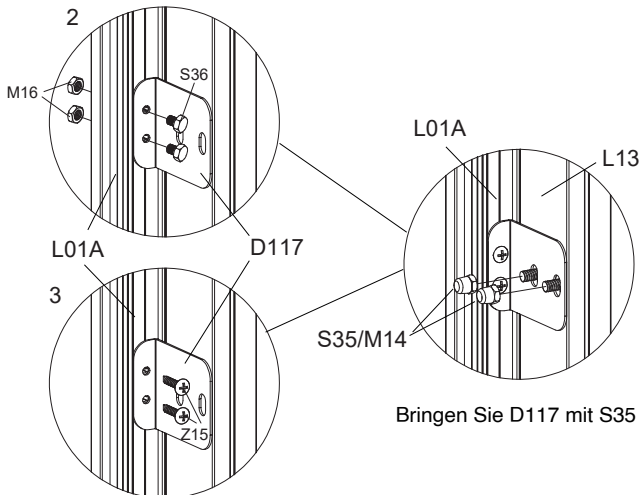

Bringen Sie D117 mit S35 & M14 an L13 an.

Es befinden sich bereits Z15 an dieser Position von L01A.

Bitte entnehmen Sie zuerst Z15, und bringen D117 wieder mithilfe von Z15 an L01A an.

Technische Daten

Modell:	400HDGH474
Abmessungen (B × T × H):	ca.91x51x140cm
Gewicht:	45kg
max. Benutzergewicht	10kg

Entsorgung

Verpackung entsorgen



Entsorgen Sie die Verpackung sortenrein. Geben Sie Pappe und Karton zum Altpapier, Folien in die Wertstoff-Sammlung.

Importeur:
monolith GmbH
Maxstraße 16 D-45127 Essen
Germany